



LIGHT WEIGHT – HEAVY DUTY **POWER TILLER**



BLITZ 80



ENGINE VARIANT

**DIESEL ENGINE
THROQ 186 F - 10 HP**

OUTSTANDING FEATURES

**NARROW WHEEL BASE OF ONLY
21 IN.(53 CMS)**

**LIGHT WEIGHT ROBUST
ALUMINUM GEAR BOX HOUSING**

**“POWER TAKE OFF” (PTO) FOR
QUICK COUPLE OF IMPLEMENTS**



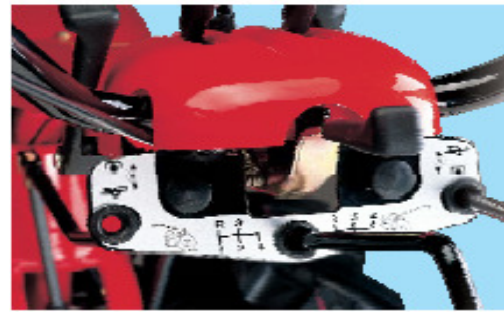
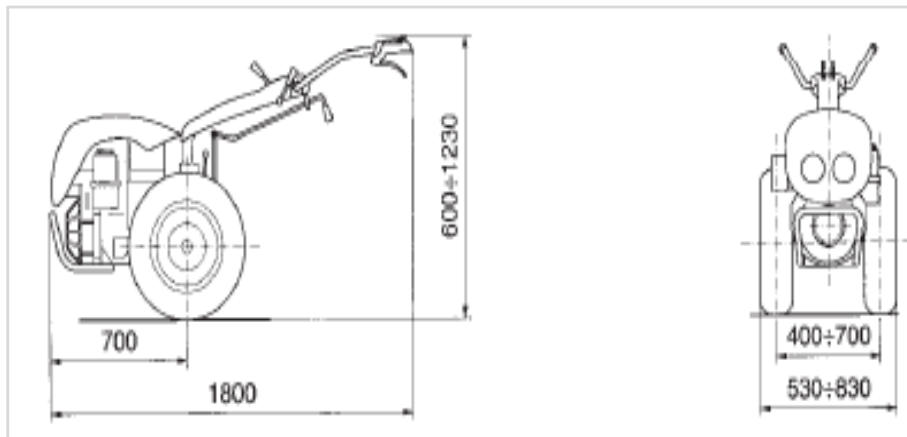

Well designed dashboard with easily understood symbols on the controls and to highlight their operating positions



Handlebars are height adjustable and can be off-set or reversed to 180° to enable the machine to be used in a wide gamut of work needs

SPECIFICATION	BLITZ 80
Engine	Thorq 10 HP
Clutch	Dry Single Plate
Gearbox	Aluminum housing – Oil filled
Normal Speed-kph	I-1.2 ;II-2.26; III – 5.08 ;IV – 15 ; Rev-1.8
Reverse Speed-kph	I-1.8 ; II-3.3 ;III – 7.4 ;IV –21.4 ; Rev-2.63
PTO –Normal Version	675 Rpm + 5 Synchronized
PTO –Reversing Version	985 Rpm + 5 Synchronized
Differential	Engage/disengage lever
Brakes	Independent mechanical on both wheels
Tyres	5.00 - 12
Handlebars	Height/Off-set adjustable and 180 Tilting
Safety	Complying with International standards
Headlights	Yes
Weight (Kgs.)	150 kg with Diesel Engine

ATTACHMENTS

DEEP HOEING

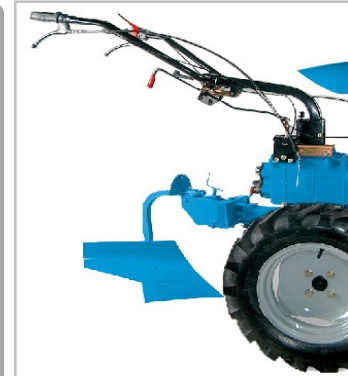

TROLLEY



SPRAY PUMP



GRASS CUTTER



PRODUCED BY

YAGMUR TARIM MAKINALARI San. ve Tic A.S
 Beymersan Sanayi Sitesi 2. Cadde No.17
 TURKEY

INDIAN PARTNERS



Agro - Commercial

8A , Camac Court, 25 B, Camac Street, Kolkata – 700016

Ph : +33-22874206 ; Fax : +33-22867304, email: info@agrocom.in , Web : www.agrocom.in